

ADAPTOR SHAFT to fit M229 ALIGN POWER FEED 8-10-15 RJD
- TO - M162D HM-53GV MILL "Y" AXIS TABLE SCREW

Sizes taken off shaft from factory on first shipment 10-2015

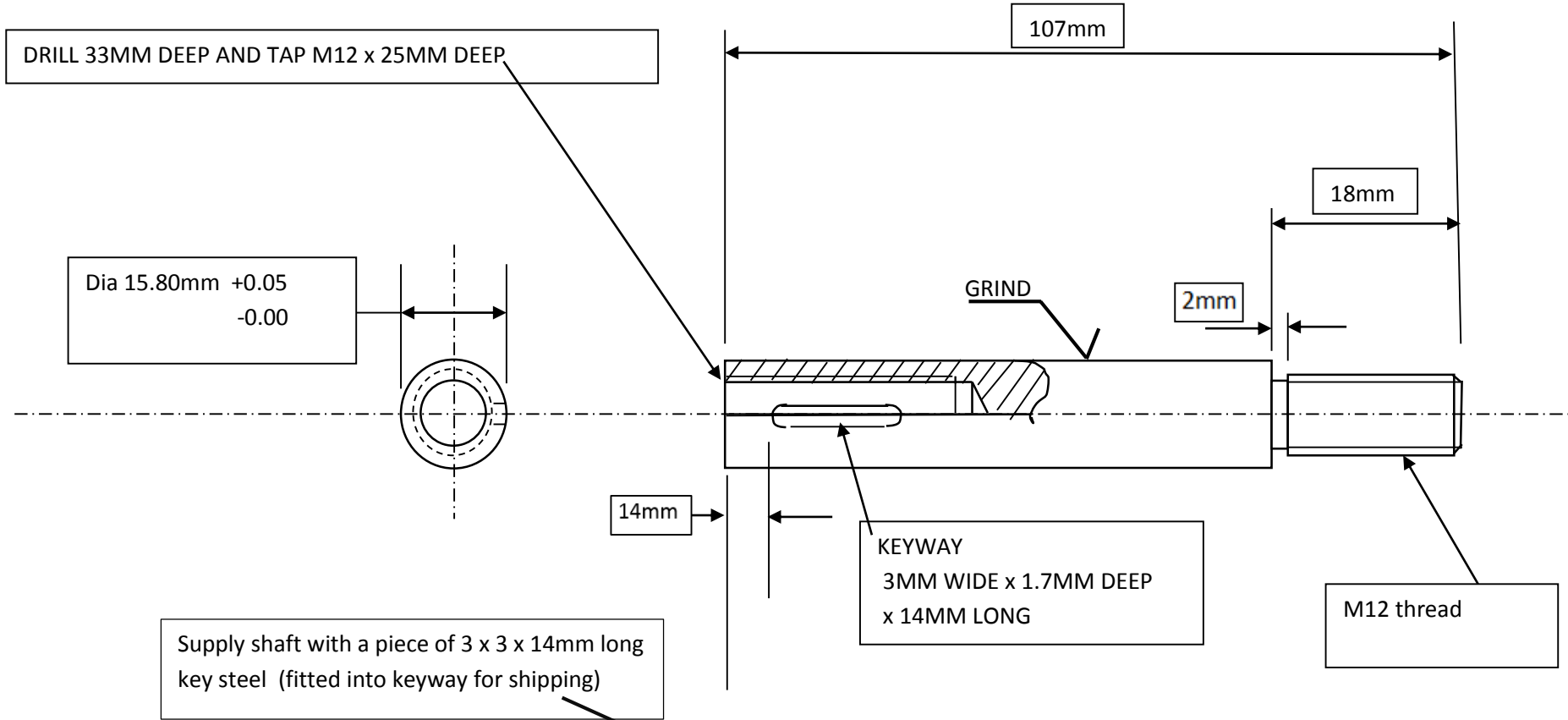

All Extra parts required to fit M229 Powerfeed onto mill

